

VEGA DAC I & II

Up to 34 GS/s, 6-bit Ultrafast Digital to analog Converters

MICRAM

Type: Module	Technology: SiGe	f_T / f_{max} : 170/250 GHz	Metallization: 4	Ref.-No.: R1038
--------------	------------------	-------------------------------	------------------	-----------------

Brief description

The VEGA DACs are a family of 6-bit digital to analog converters with >18 GHz bandwidth. Key features include:

- DAC I sampling rate variable from 1 to 25 GS/s
- DAC II sampling rate variable from 1 to 34 GS/s
- Programmable maximum output amplitude
- FPGA compatible 24 channel data interface
- Programmable FPGA reference clock divider
- SONET-PRBS de-scrambling option for inputs
- Optional on-chip SerDes synchronization
- Single-ended and differential operation
- Serial config/calibration register (LVTTTL)

The VEGA DAC analog differential output, which can also be used single ended, has a full scale amplitude of 800 mV swing. The analog output path has a bandwidth of 20 GHz to generate best possible signal slopes at maximum amplitude.

Conversion is driven by a half-rate clock (i.e. 15 GHz for 30 GS/s). To adjust the sampling points or to synchronize two VEGA DACs, the sampling phase can be adjusted in a 100 ps range.

The 6-bit binary conversion inputs are multiplexed by 4 and sent via a 24 channel LVDS/PCML interface. This interface is compatible with Virtex 4/5/6 and Stratix-IV FPGAs with high-speed SerDes. For channel synchronization as well as DC-balancing an on-chip SONET descrambler can be enabled.

Finally, the VEGA DACs provide a programmable reference clock divider to drive the FPGA and a LVTTTL register interface for configuration and calibration.

Typical applications for the VEGA DACs include:

- 40G & 100GbE applications for DQPSK/OFDM
- Test and measurement applications
- Arbitrary Waveform Generation
- Preemphasis

Package

VEGA DAC modules are equipped with K-connectors for clock and analog outputs. All other signals are carried out on 4 Samtec connectors.

VEGA DAC module

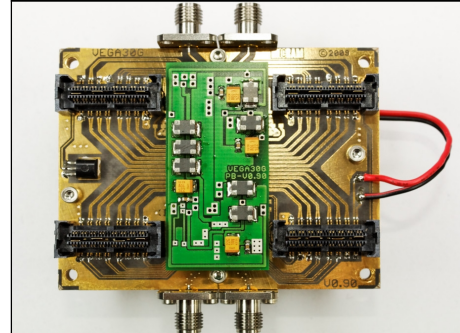

VEGA DAC block diagram

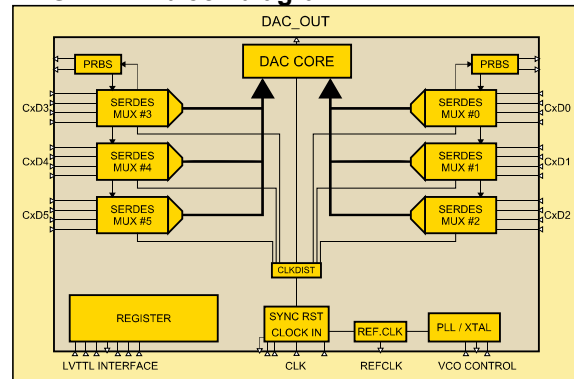

VEGA DAC electrical data

Power supplies:	+3.3V, +1.5V, -3.3V, -4.5V
Power dissipation:	10 to 13 W
Clock rates: DAC I	0.5 to 12.5 GHz
DAC II	0.5 to 17 GHz
Full analog output swing:	800 mV se
Bandwidth:	20 GHz
ENOB:	> 4.0 @ 5 GHz

VEGA DAC II measured results

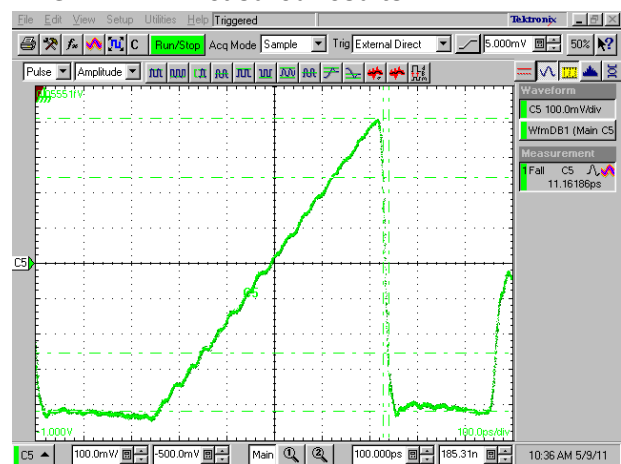

Example: 16 step ramp @ 34 GS/s

www.micram.com

Germany: +49-234-9708-300 USA: +1-650-678-0389

Copyright 2009, all rights reserved. Product specifications are subject to change without notice.

MICRAM

We design. You win.

VEGA DAC I & II

Up to 34 GS/s, 6-bit Ultrafast Digital to analog Converters

MICRAM

Type: Module	Technology: SiGe	f_T / f_{max} : 170/250 GHz	Metallization: 4	Ref.-No.: R1038
--------------	------------------	-------------------------------	------------------	-----------------

DAC Module mounted on VEGA evaluation board (with power supply module attached)

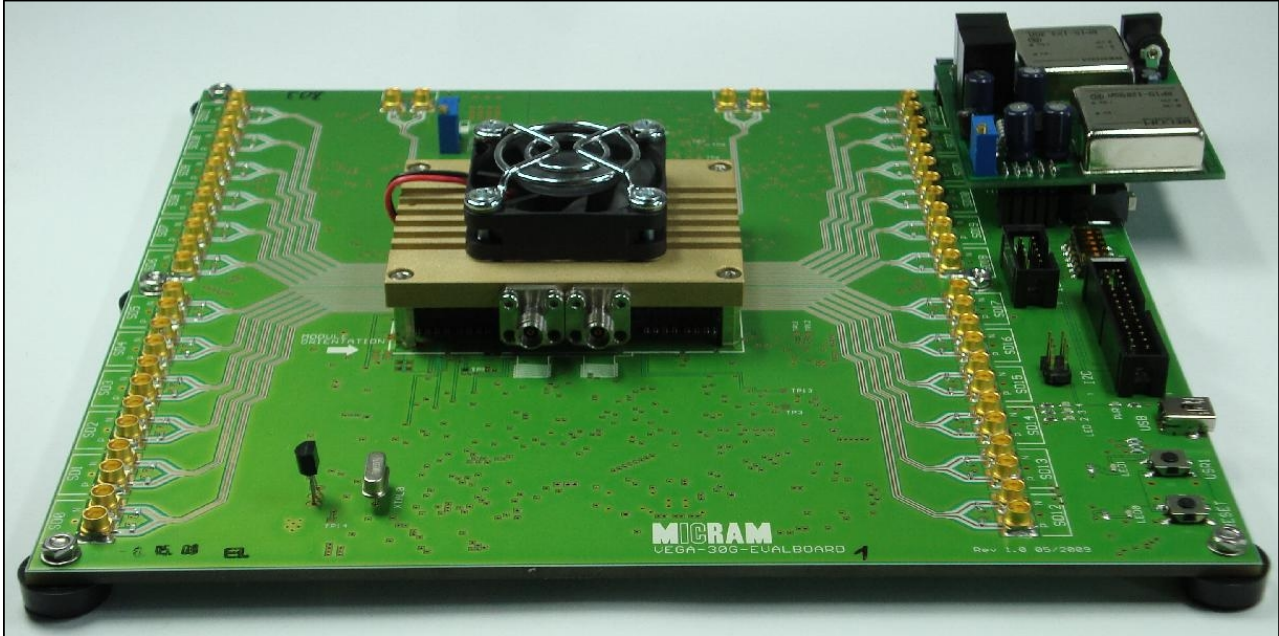

The VEGA evaluation board can be used to mount VEGA DAC modules for easy deployment in a laboratory environment. The board incorporates a microcontroller for communication with a PC via a USB 2.0 connector. VEGA board firmware allows easy setup of VEGA DAC operating modes as well as read/write access to all internal registers.

Optionally an FPGA connector can be used to control VEGA DACs directly from an FPGA. The 24 differential lines of the digital inputs are accessible by SMP connectors. Clock input and the analog output are connected directly to the VEGA DAC module via K-connectors.

VEGA evaluation board (bottom)

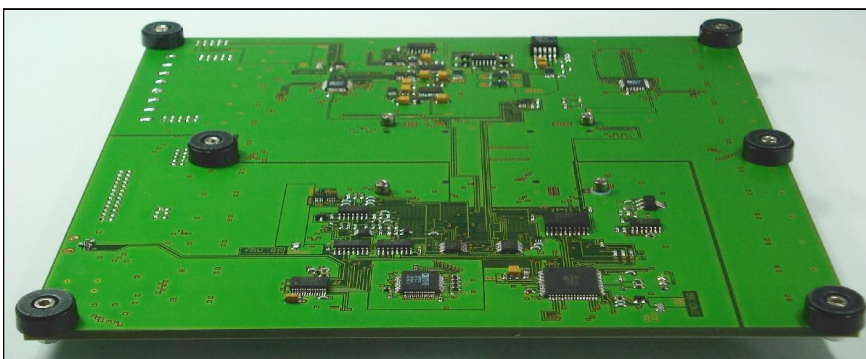

VEGA power supply module

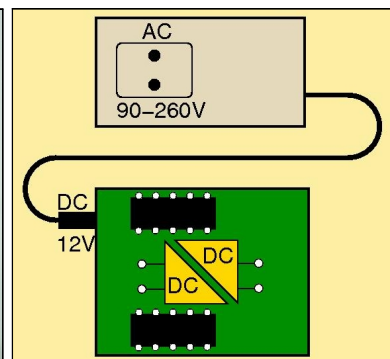

Micram offers a matching power supply module and preconfigured RF cable sets (RG 316/U standard). For further information on the VEGA DAC family, please contact your Micram sales representative.

www.micram.com

Germany: +49-234-9708-300 USA: +1-650-678-0389

Copyright 2009, all rights reserved. Product specifications are subject to change without notice.

MICRAM

We design. You win.